

YASHICA

38-70mm ZOOM COMPACT CAMERA

Thank you for your purchase of this camera. To use your camera correctly, please read this manual carefully before using it.

En optant pour cet appareil de photo, vous avez fait le bon choix. Pour en exploiter toutes les possibilités, nous vous recommandons de lire attentivement ces instructions avant de prendre vos premières photos.

Names of Parts

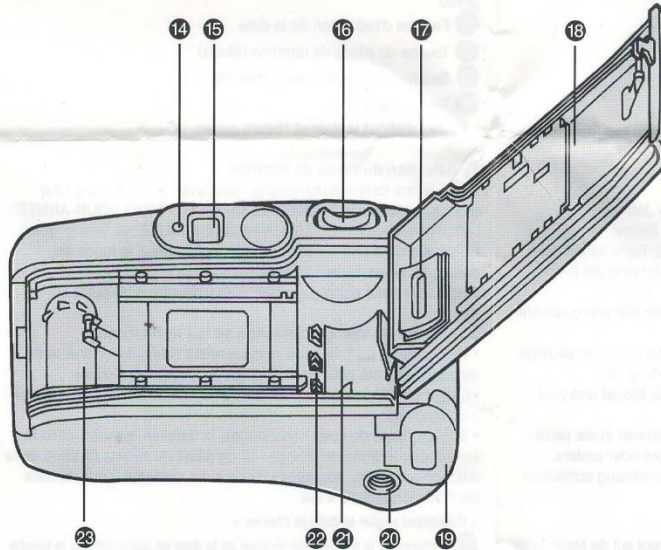
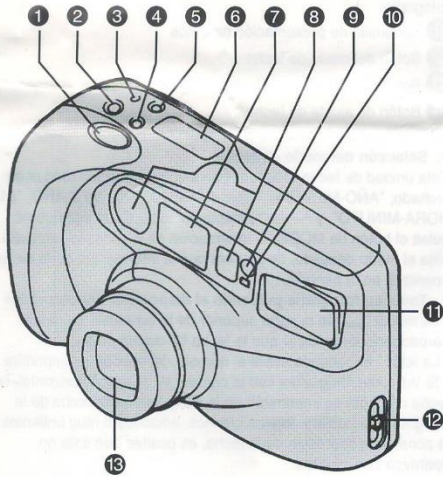

• Viewfinder • suchte
• Visueur • Visor

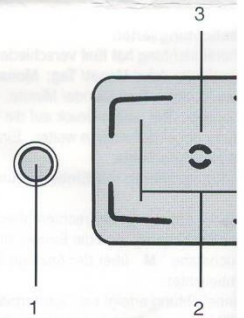

1. Shutter Release Button
2. Main Switch
3. Manual Rewind Button
4. Self-timer Button
5. Picture - taking Mode Button
6. Display panel
7. Viewfinder Window
8. Auto-focus Windows
9. Self - timer indicator / red-eye reduction lamp
10. Light Sensor
11. Flash
12. Camera Back Release Knob
13. Taking Lens / Lens Cover
14. Green LED
15. Viewfinder
16. Zoom Button
17. Film Check Window
18. Camera Back
19. Battery Compartment Cover
20. Tripod Socket
21. Film Chamber
22. DX Contacts
23. Spool

Advanced Techniques

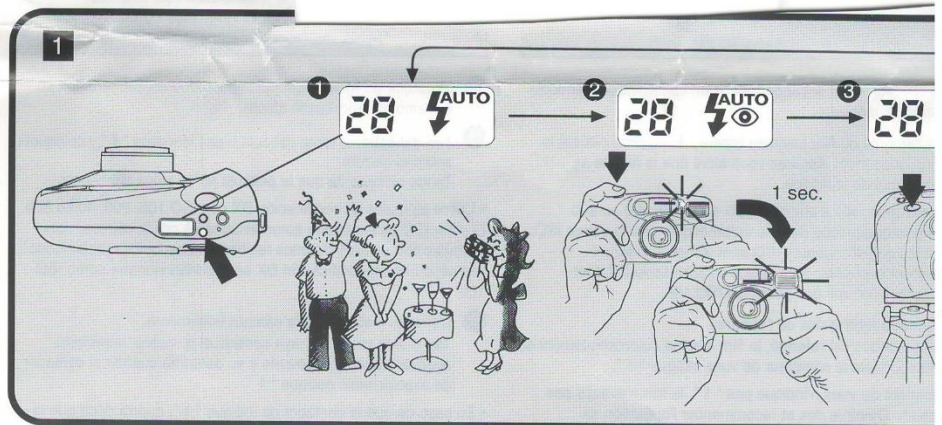

Viewfinder

1. GREEN LED
 - Activated with the main switch on:
 - Blinks: While the flash is charging.
 - Goes out: When the flash is fully charged.
 - Activated by depressing the shutter release button halfway:
 - Lights up: When the subject is in sharp focus.
 - Blinks: When the subject is not in focus because it is too close.
2. Picture Area Frame:

You will get in your picture everything you see through this frame.
3. Focus Frame:

The frame for focusing on the subject. (Center of the viewfinder)

Basic Operations

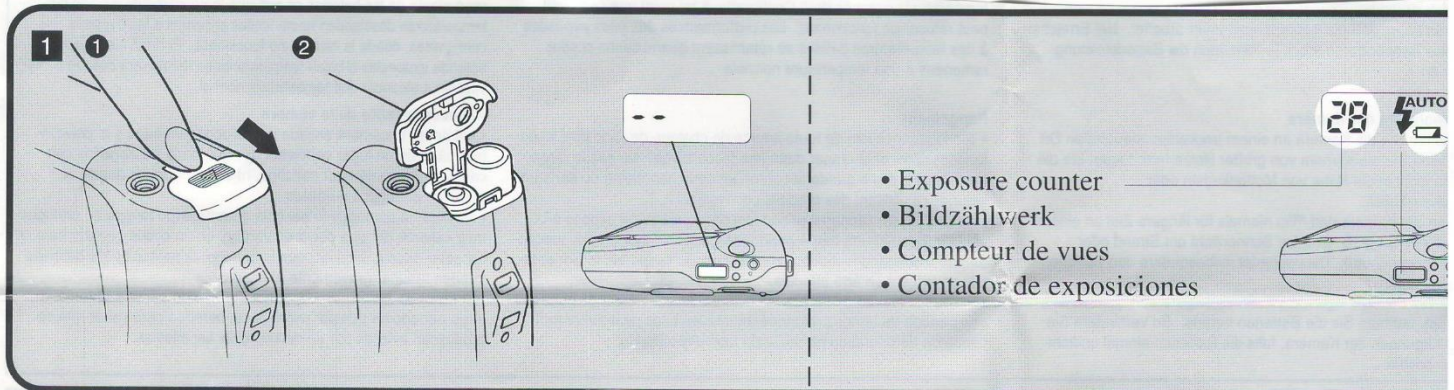

5 Take Your Picture

Aim the focus frame in the center of the viewfinder at your subject and depress the shutter release button halfway. The lens will focus itself on the subject and the green LED beside the viewfinder eyepiece will light up when the subject is in sharp focus. Then depress the shutter release button all the way to take your picture.

- The camera is in the automatic flash activation mode when it has turned on. In dim light, the flash will fire automatically.

The shooting range is as follows:

ISO 100	Wideangle (38 mm)	Telephoto (70 mm)
Shooting in Daylight	Approx. 1.1 m - ∞ (3.6 ft. - ∞)	Approx. 1.1 m - ∞ (3.6 ft. - ∞)
Shooting with Flash	Approx. 1.1 - 4 m (3.6 ft. - 13.2 ft.)	Approx. 1.1 - 2 m (3.6 ft. - 8.6 ft.)

- If the green LED blinks, the subject is too close. Change the shooting distance so that it stops blinking, shoot.
- After the flash has fired, it will immediately start to recharge itself. While it is recharging, the green LED will blink. When it turns off, the flash is fully charged.
- During flash charging, the shutter cannot be released.

< HOLDING THE CAMERA >

- Hold the camera firmly with both hands.
- To take pictures with the camera in vertical position, always hold it with the flash side up.
- Do not cover the flash reflector with your fingers, camera strap, etc.

6 Focus Lock

If your subject is not in the focus frame, use the focus lock.

- Aim the focus frame at the subject you want to focus on, and depress the shutter release button halfway.
- As soon as the subject is in sharp focus, the green LED beside the viewfinder eyepiece will light up (the focus is locked).
- While holding the shutter release button depressed halfway, recompose your picture then take it by depressing the button all the way.
- The focus is locked while the shutter release button is depressed halfway, so the subject will remain in sharp focus even if you move the camera without changing the shooting distance.
- The focus lock is released if you remove your finger from the button.

< Subjects that are not easy to focus >

In the following cases, the camera's auto-focusing system will not operate properly. In this case, use the focus lock. First, focus the lens on an object locked nearby at the same distance, activate the focus lock, then shoot.

- When the subject has no fixed shape; for example, fireworks and smoke.
- When the subject has a glossy surface; for example, car body and water surface.
- When the subject does not reflect light, such as hair, for example.
- Subjects taken through a window pane.
- Extremely small objects.

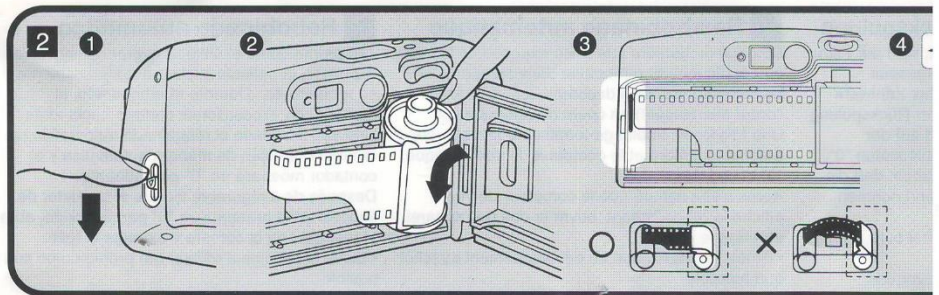

2 Taking pictures with the Self-Timer

Use the self-timer button when you are taking a group photo and want to include yourself in the picture.

- Secure the camera with a tripod or the like and decide on your composition.
 - Direct the focusing frame toward the subject and press the self-time button.
- The Self-timer indicator lamp will blink, and the shutter will trip after approximately 10 seconds.
- During operation of the self-timer the exposure counter becomes a display showing the time (seconds) remaining until the shutter is tripped.
 - If you wish to stop the self-timer while it is operating, press the self-timer button again.
 - The shutter will trip if the shutter release is pressed during self-timer operation.

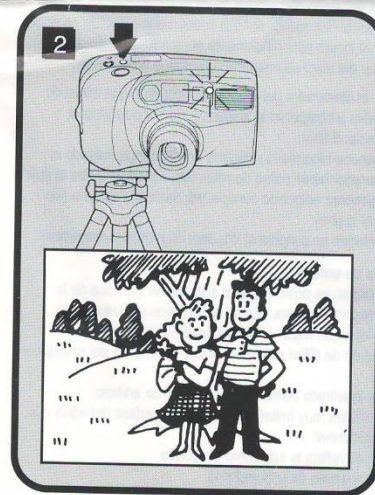

7 Automatic rewinding

As soon as the last frame is exposed, the film will automatically start to wind itself back into its cassette. While it is rewinding, the Exposure Counter will count down. When it has wound itself back completely, it will stop automatically and the Exposure Counter will show "0", and blink.

After making sure the Exposure Counter blinks at "0", open the Camera Back and take out the film.

- Take the exposed film for processing as soon as possible.
- To rewind the film in the middle of a roll, press in the Manual Rewind Button. (Do not use a sharp-pointed object such as a needle to press it in.)

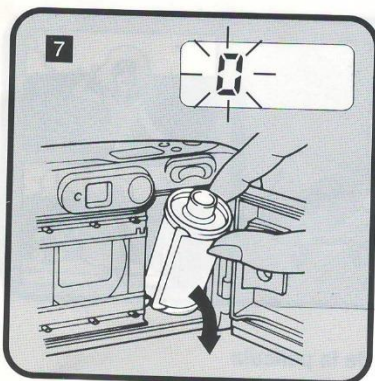



1 Insert the battery

- 1 Open the battery compartment cover by pushing it in the direction of the arrow and lifting it.
- 2 Insert the battery as illustrated inside the battery compartment and close the cover.

• When only the exposure counter is displayed on the display panel and the "  " (battery warning mark) is not displayed, the battery voltage is normal.

< Battery replacement >

When the "  " mark is displayed on the display panel, time to replace the battery. Switch off the camera power and replace the battery.

You can still shoot after the "  " mark comes on, but replace the battery as soon as possible. If the battery capacity falls below the specified limit, all the displays disappear from the display panel and the camera does not work.

Be sure to use alkaline batteries.
Penlight type lithium batteries or rechargeable nickel-cadmium batteries cannot be used.

• Battery precautions •

Observe the following precautions when loading the batteries, otherwise the camera may malfunction.

- (1) Always use batteries with their (+) and (-) ends correctly.
 - (2) Do not mix old and new batteries.
 - (3) Load the batteries with their (+) and (-) ends correctly.
 - (4) Do not use nickel-cadmium batteries.
- Battery performance will be reduced temporarily in low temperatures. If you are shooting in cold weather, keep the camera warm inside your jacket and take it out only when needed.
 - Poor contact may result if battery poles are soiled with sweat or grease. Wipe both poles clean before loading the batteries.
 - Bring spare batteries with you if you are going on a long trip.
 - Do not throw used batteries into a fire and do not charge, short, disassemble or heat them because it is dangerous.

2 Loading the film

- 1 Open the Camera Back by pushing down the Camera Back Release Knob.

For film, we recommend ISO400 type film, which is good for flash photography and for preventing camera shake.

- 2 Insert the film cassette sidewise with its top end first.
- 3 Pull the tip of the film up to the " 1 " mark and place it on the top of the spool.
Be careful at this time that the film does not float up from the spool.

• Use DX-coded film with ISO speeds of 100, 200, 400, or 800. The film speed is set automatically. Caution is required, however, because you cannot get correct exposure if you use DX-coded films with other ISO speeds.

If you use non-DX-coded films, the film speed will automatically be set to ISO 100.

- 4 Close the Camera Back securely.
As soon as the Camera Back is closed, the film will automatically advance and stop when the Exposure Counter shows " 1 ".
- If the counter does not show " 1 ", the film is not advancing properly. Open the Camera Back and load the film correctly again.

3 Press the main switch to turn "ON" the camera power.

When you press the main switch, the camera power comes "ON" and you are now ready to take pictures.

- When the camera power is switched on, the flash is charged. During the charging the Green LED blinks and when the charging comes complete, the Green LED goes out and you are ready for flash shooting.
- When you press the main switch again, the lens retracts the lens barrier closes, and the camera power goes off.
- Make it a rule to switch off the power when you do not use the camera soon. This prevents accidental shooting.

< Automatic power-off >

To conserve the battery power, if the camera is left unused for about 3 minutes with the power-on, the lens retracts, the lens barrier closes, and the camera power goes off.

- When you press the main switch again, the power comes "ON".

4 Compose Your Picture with the Zoom Button

While watching your subject through the viewfinder, compose your picture by pressing the zoom button on the side "W" (wideangle) or "T" (telephoto).

- The shutter will not trip while the lens is zooming.

1 Taking-pictures Using the Picture-taking Mode Button

Each time you press the picture-taking mode button the picture-taking mode switches to the next mode in this sequence:

1. automatic flash mode (the mode the camera goes into when you switch it on)
2. red-eye reduction automatic flash mode
3. on-demand flash mode
4. red-eye reduction on -demand flash mode
5. no flash mode
6. landscape mode.

The mode in use is displayed on the display panel. Take your pictures in whichever mode you want.

1 < Auto flash mode >

This is the mode the camera goes into when the main switch is turned on.

In dim locations, the camera switches automatically to flash shooting.

2 < Red-eye reduction auto flash mode >

When there is not much light, a person's pupils sometimes come out red when using the flash. In order to reduce this effect, the red-eye reduction lamp will light up for about 1 second when depressing the shutter release, then the flash will fire. Take care that neither the camera nor the person moves until the flash has fired.

- The flash conditions are the same as for auto flash mode. The flash lights automatically if the subject is too dark.

3 < On-demand flash mode >

In this mode, the flash fires for every picture. Use this mode when shooting scenes in which the surroundings are bright but the subject is in the shadow, for example, a person standing near a window, and for taking pictures of people against an evening or night background. This mode can bring the background light and scenery to life and capture people beautifully.

4 < Red-eye reduction on-demand flash mode >

This mode combines the " 3 " on demand flash mode with the red-eye reduction mode. For details on red-eye reduction please look under " 2 Red-eye reduction auto flash mode ".

5 < No flash mode >

For taking photographs without flash, for example to capture the mood of a sunset or indoors, use this mode.

Since the exposure is determined according to the brightness of the subject, photographs can be taken with a natural feel.

6 < Landscape mode >

Set to this mode when you want to photograph distant scenery or scenes on the other side of a glass window. You will be able to obtain sharper pictures.

- The flash will not operate in this mode.
- After photographing in the Landscape Mode, the camera will return automatically to the Automatic Flash Activation Mode.

Note for no. 3, 4, 5, 6

In dim light, the shutter is released slowly. Use a tripod to keep the camera from shaking.

Printing the Date or Time

(This chapter is provided only for models equipped with a dating unit.)

The dating unit allows you to print the date or time in your picture.

- 1 Date Display Window
- 2 Date Mode Button
- 3 Date Select Button
- 4 Date Set Button

• First, set the correct date and time.

1. Choose the dating mode.

The auto-dating unit has five dating modes: year/ month/ day, month / day / year, day / month / year, day / hour/ minute and "-- --" (no imprint). Each time the MODE button is pressed, the display of the dating mode changes. Choose the desired mode from the date display window.

2. Take your picture by depressing the shutter release button

- The mark " — " in the top right corner of the display window will blink to tell you that the date has been printed.
- The letter "M" above the number stands for Month; it will not be printed.
- If you take pictures with the camera in horizontal position, the date or time will be printed on the bottom right corner of the picture. If there is a white, yellow or other bright-colored object in the position where the date is printed, the date number will not show up clearly.

< How to correct the date and time >

- 1 Press the date mode button to show the number you want to correct.
- 2 Press the date select button so that the number you want to correct blinks.
- 3 Press the date set button to set the correct number. (If the time display shows " : ", you can set the correct time from zero second. To set it, press the date set button simultaneously with a time signal.
- 4 After completing the correction, press the date select button until the number stops blinking.

• Replacement of the battery for the data back

The data back uses a long-life lithium battery (CR2025) which lasts about three or four years. If it is spent, however, the date or time will not show up clearly on your picture or the liquid crystal display will function erratically. In this case, replace the battery as indicated in the illustration.

Camera Care

- Fingerprints and dirt on the lens and other areas can affect the accuracy of the camera. If the camera is soiled, wipe off gently clean the surfaces with a soft lens cleaning tissue moistened with lens-cleaning solution. Remove dust off by using with a blower brush.
- Use a soft cloth to clean the camera body. Never use organic solvents such as thinner or benzene.
- Wipe the camera clean after use at the seaside or in dusty areas. Salt air will have a corrosive effect on the camera; sand and dust will be harmful to the camera mechanism.
- The lens may cloud if the camera is suddenly brought into a warm room from cold outdoor temperatures. Although this cloud will eventually disappear, avoid as much as possible exposing the equipment to sudden temperature changes.
- This camera includes dangerous high voltage circuits. In case of malfunction, never attempt to disassemble the camera by yourself.
- **When using the camera for important occasions such as trips abroad or weddings, ensure operation beforehand or take test photographs to confirm proper operation. We also suggest bringing along a spare battery.**
- This camera is a precision instrument. Do not drop it or expose it to intense shock.
- When using the camera in cold areas, store it inside clothing when not in use, remove it only to take pictures. Battery performance will be temporarily reduced when temperatures drop to near 0 degrees Centigrade to the point that the camera will not operate. The function of batteries exposed to low temperatures will be restored when the batteries are returned to normal temperature.

Camera Storage

- Keep the camera away from heat, moisture and dust and store it in an airy place. Do not store it in a wardrobe drawer containing moth balls or in a laboratory handling chemicals.
- Do not leave the camera and film for a long time in a hot place (on an ocean beach in summer, in a closed car under direct sunlight, etc.) as the camera, film and battery may be adversely affected.
- If you are likely to use the camera for long period, remove the batteries to prevent damage due to battery leakage.

Specifications

Type: All-automatic 35mm lens shutter camera with built-in zoom lens.
Lens: 38mm F5 . 2 - 70mm F9 . 1 (5 elements in 5 groups).

Shutter: Programmed electronic shutter.

Exposure control: Programmed automatic exposure, EV5-EV16 (ISO 100).

Film speed: Automatic setting with DX-coded ISO 100, 200, 400, 800 film.

Film speed automatically set to ISO 100 with non-DX coded film.

Focusing: Auto focus, provided with focus lock; about 1.1 m/3.6ft. - ∞ focusing range.

Viewfinder: Albada type bright frame zoom finder.

Display in Viewfinder: Shooting area frame, focus frame.

Display beside Viewfinder eyepiece: Green LED (focusing and flash charging indicator).

LCD panel: Exposure counter/self-timer count down, battery warning mark, picture-taking mode marks (Automatic flash activation, Red-eye reduction auto flash, On-demand flash, red-eye reduction on-demand flash, No flash, Landscape mode).

Film loading: Auto loading (film automatically advances to the first frame).

Film advance: Automatic.

Film rewinding: Auto return/auto stop and a mid-roll film can be rewound.

Self-timer: Electronic, with about 10-sec. delay (self-timer indicator/ red-eye reduction lamp blinks while it is operating); exposure counter shows remaining time in seconds.

Flash: Built-in, flashmatic type.

Recycle time: about 6 sec. (at normal temp. with fresh batteries, according to the company's standards).

Shooting distance: About 1.1 m/3.6 ft. - 4 m/13.2 ft. at 38 mm, about

1.1 m/3.6 ft. - 2 m /6.5 ft. at 70mm (ISO 100 color negative film).

Batteries: Two 1.5V alkaline penlight batteries; about 10 rolls of 24-exposure film can be exposed with 50% flash (at normal temperature with fresh batteries, according to the company's standards).

• Auto dating unit (for models with data back only): Built-in LCD display quartz watch (automatic calendar).

Date imprinting method: year-month-day, month-day-year, day-month-year, day-hour-minute, dating unit off.

Battery for dating unit: 3V lithium battery (CR2025) 1 pce.

Dimensions & Weight: 129(W) x 72(H) x 47.5(D) mm (5-1/8 x 2-7/8 x 1-7/8 in.), about 245g (8.64 oz.) without data back (without batteries).
129 (W) x 72 (H) x 50 (D) mm (5-1/8 x 2-7/8 x 2 in.), about 250 g (8.82 oz.) with data back (without batteries).

Specifications and design are subject to change without notice.